

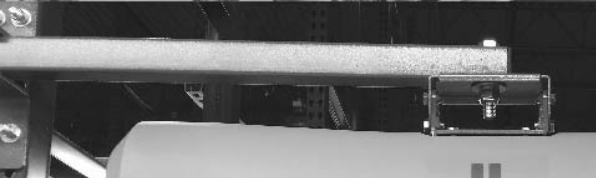

PATTERSON FAN MANUAL

Operating, Installation & Parts Manual (OIPM)

Patterson Fan Company, Inc
Blythewood, SC 29016
www.pattersonfan.com
800.768.3985



Contents Page

| | |
|--------------------------|---------|
| Assembly Instructions | 3 - 10 |
| Maintenance Instructions | 12 - 14 |
| Troubleshooting | 15 |

YM Yoke Mount Assembly Instructions

There are many acceptable methods for hanging a Patterson Yoke Mount fan. The yoke must be securely connected to a solid structure and that all materials used to hang the yoke and fan must be rated for this type of rigging and workload. Below is what we consider to be the simplest method of fan suspension. Feel free to improvise, but please use caution and good judgment.

1. Secure the "U" shaped yoke to the object from which you intend to mount the fan. Use a 5/8" bolt, a 5/8" nut and (2) 5/8" washers. Tighten the nut onto the bolt using a 5/16" bolt end wrench and ratchet with 5/16" socket.
2. The factory assembled fan head fits inside of the "U" shaped yoke, the threaded studs on each side of the fan fit through the predrilled holes on the "U" shaped yoke. Secure the factory assembled fan head to the "U" shaped yoke with the supplied nuts. Mount the factory assembled fan head so that the motor capacitor is in up position.
3. If safety cable installation is desired (recommended), use a length of chain or cable to secure the fan to a solid surface and attach to the fan. Make sure cable or chain is rated for the weight and purpose of securing the fan.



PS Pedestal Stroller Assembly Instructions

There are many applications for the Patterson Pedestal Stroller Fan. Use care when selecting locations for the fan. Do not place the fan on a sloped surface. Do not use if the finger guards are missing, damaged or not fitting properly. Do not use if the cord or connector has exposed wires or is damaged in any way.

1. Place the pedestal stroller on a flat surface.
2. Secure the "U" shaped yoke to the pedestal stroller by inserting the 5/8" bolt through the center hole in the yoke and through the hole in the pedestal stroller arm. Place the 5/8" nut on the 5/8" bolt and tighten securely.
3. Carefully mount the factory assembled fan with mounting studs through the holes in the uprights of the "U" shaped yoke with the motor capacitor is in up position. Secure the fan to the yoke with the factory supplied nuts.

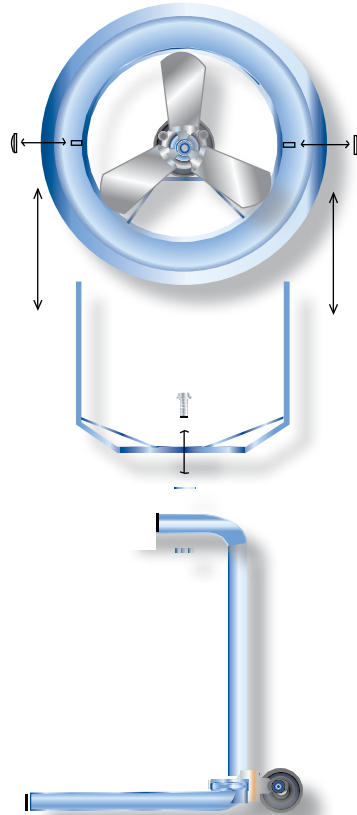

Note: Due to continual product improvement, items are subject to change without notice.

YM Yoke Mount Assembly Instructions (34" Fan Only)

There are many acceptable methods for hanging a Patterson Yoke Mount 34" fan. The yoke must be securely connected to a solid structure and all materials used to hang the yoke and fan must be rated for this type of rigging and workload. Below is what we consider to be the simplest method of fan suspension. Feel free to improvise, but please use caution and good judgment.

1. Assemble the yoke connecting Side A with Side B to the stud bolts of the fan housing. The factory assembled fan head fits inside the "U" shaped yoke, the threaded studs on each side of the fan fit through the predrilled holes on the "U" shaped yoke. Secure the fan head to the yoke with the supplied nuts.
2. Assemble Side A and Side B of the yoke and connect with supplied bolt.
3. Safety cable is mandatory. Use a length of chain of cable to secure the fan to a solid surface and attach the fan. Make sure cable or chain is rated for the weight and purpose.

Note: Due to continual product improvement, items are subject to change without notice.

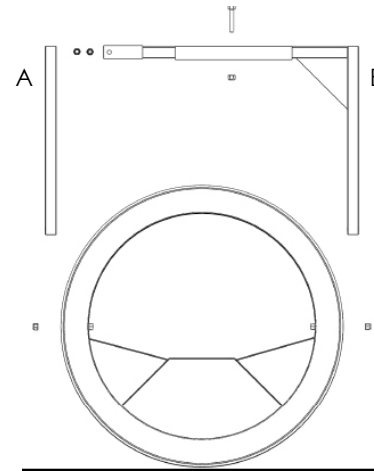

TC Truck Cooler Assembly Instructions

Important things to remember: the wall mount should be a solid structure able to support the weight of the fan safely and the fan should not be at a height that will cause employees to bump their heads. Ideally, the fan should be mounted to blow into the back of the truck down the top corner of either side of the trailer.

1. Secure the wall bracket and arm to the solid surface where you will hang the fan. A structurally secure solid wall or beam is best.
2. Secure the "U" shaped yoke to the arm of the wall bracket. Use the 5/8" bolt and 5/8" nut supplied. Tighten the nut onto the bolt using a 5/16" box end wrench and ratchet with a 5/16" socket. **For clearance reasons, the "U" shaped yoke must open down.**
3. The fan head fits inside the "U" shaped yoke, the threaded studs on each side of the fan fits through the predrilled holes on the "U" shaped yoke. Secure the fan head to the "U" shaped yoke with the supplied nuts. Mount the fan head so that the motor capacitor is in its up position.

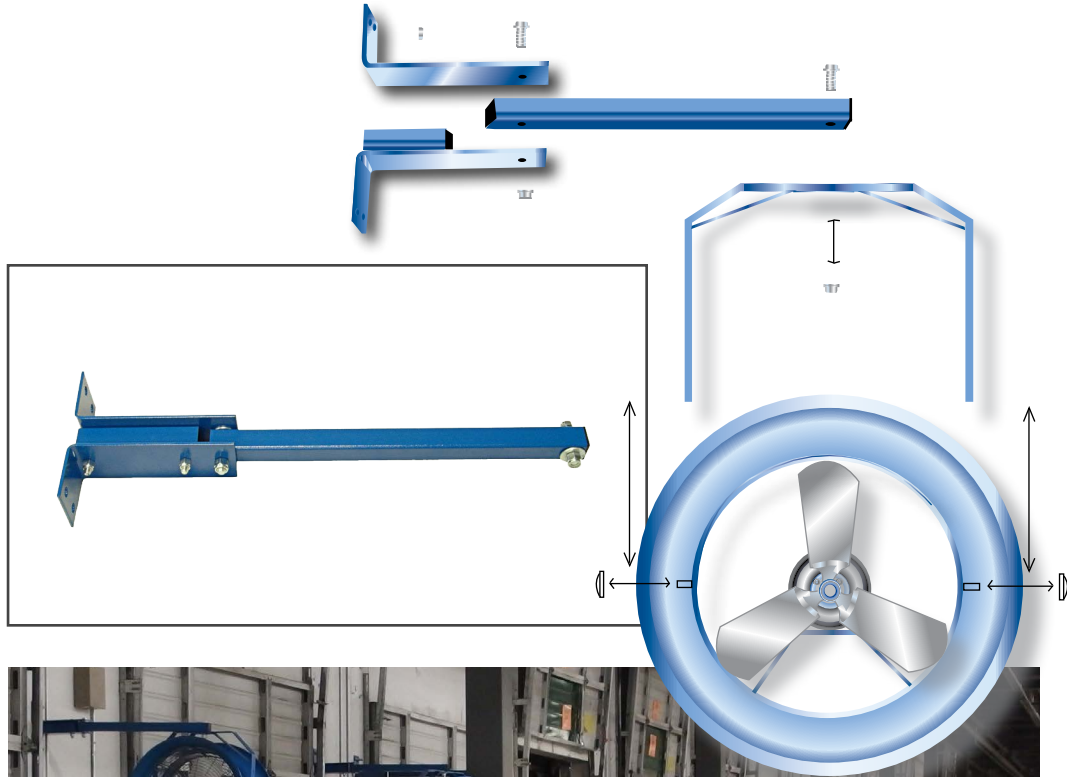

Note: Due to continual product improvement, items are subject to change without notice.

CW Column-Wall Assembly Instructions

Important: If the fan is at a level near people, it should be equipped with OSHA approved Patterson finger guards. Please contact your factory sales representative to order.

1. Secure (A) of the wall bracket to the solid surface from which you will hang the fan. There is a single mounting hole on the short end of the part. Secure (A) using a wall anchor, etc. (wall anchor not included). Place a level on the part.
2. Position (B) under (A) as shown and situate (B) in such a way so that (A) becomes level. Mark (B) for the hole. Attach (B) using the appropriate wall anchor (not included).
3. Secure the "U" shaped yoke to the wall bracket using the supplied 5/8" bolt and nut. If you plan to add an oscillator, mount the yoke so that it opens up. The bolt must go through all three pieces. Check for level and stability.
4. The factory assembled fan head fits inside of the "U" shaped yoke. Secure the fan head to the yoke with the supplied nuts. Mount the fan head so the motor capacitor is in up position.

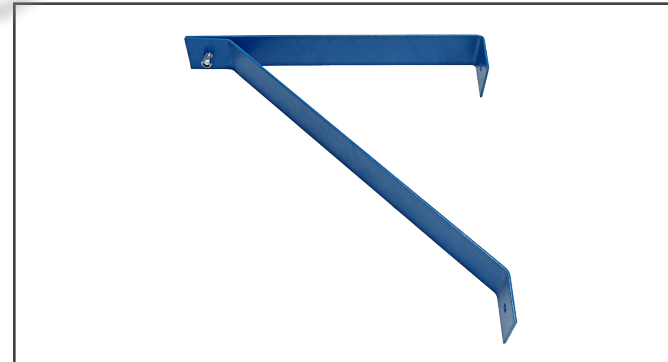
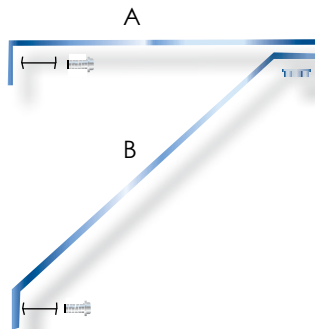
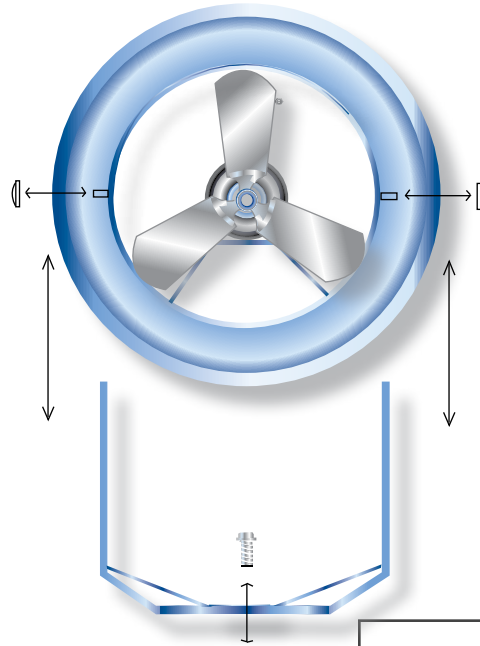

Note: Due to continual product improvement, items are subject to change without notice.

The fan head is equipped with OSHA compliant finger guards. Mount the fan at desired height making sure the fan is not in the headway of personnel, preferably out of reach. These fans are powerful and should not be mounted too close to personnel at work stations.

1. See yoke mount instruction for yoke-to-fan assembly.
2. Assemble the column-wall bracket as followed. Secure (A) (horizontal bottom strut) to the solid surface from which you will hang the fan either a wall or column using appropriate wall anchor (not included). (A) has a wall mount bracket with a 4 hole pattern for mounting to surface.
3. Secure (B) to the wall allowing the bolt hole to lineup where the fan yoke will be bolted to the column wall bracket. The fan head and yoke are suspended below the column wall bracket allowing full 360° rotation left and right.
4. Secure the "U" shaped yoke to the end of the column-wall bracket where (A) and (B) converge using the bolt supplied. The yoke allows a 30+-degree tilt toward the floor for directing air throw as desired.
5. A safety cable is mandatory. Use a length of chain or cable to secure the fan to a solid surface and attach the fan. Make sure cable or chain is rated for the weight and purpose.

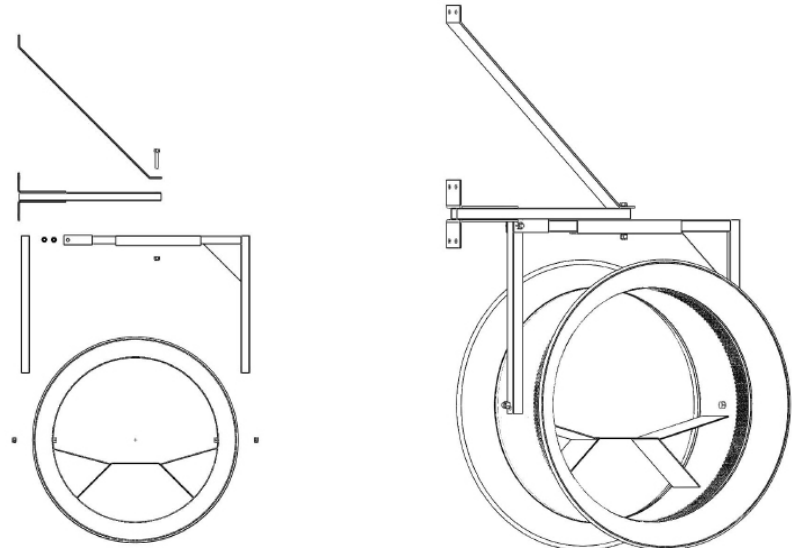
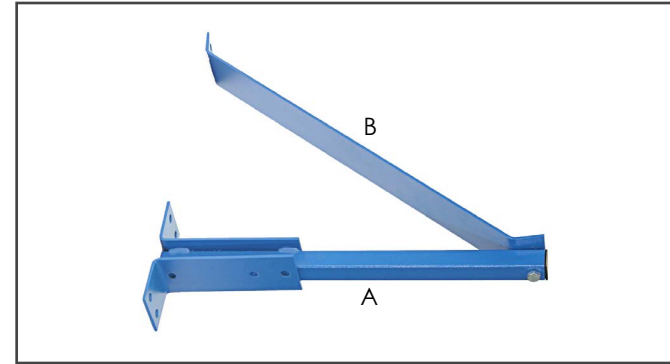

Note: Due to continual product improvement, items are subject to change without notice.

HV Ceiling Suspended Assembly Instructions

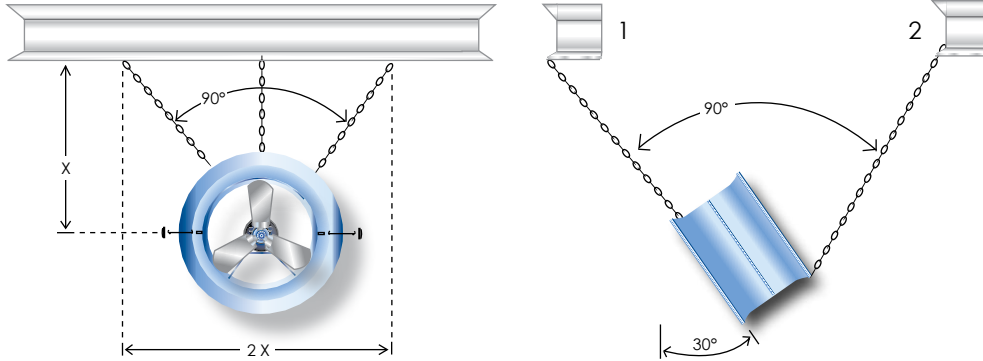

1. Facing outlet of fan, drill (2) 5/16" diameter holes (1/2" for 34" fan) one at 10:00 and one at 2:00 position in front flange. Facing the inlet side of fan, drill (1) 5/16" diameter hole (1/2" for 24" fans) at the 6:00 position in rear flange. Holes should be drilled just behind the bead of the fan housing.
2. Attach two eyebolts to holes in top front of fan. Attach third eyebolt to back rear hole in fan.
3. By means of a mechanical lift (cherry picker, scissor lift, etc.) get the factory assembled fan head to the point where you plan to suspend it. You will need three lengths of chain, three connectors, hardware for chains and bolt cutters.
4. Secure two lengths of chain to the beam or girder (1) about two times the distance apart that the fan will hang down (see diagram). The third length of chain should be centered between the two front lengths of chain and attached to beam (2). Attach the chains to the beams using your preferred method.
5. Connect the lengths of chain to the eyebolts on the factory assembled fan head using the chain connectors.
6. Rough focus the fan on your target while on the mechanical lift.
7. Get a co-worker to stand at the target mark. Make sure the power is turned off. Have someone plug the fan in. Let the fan run for approximately 30 seconds (to get up to speed and settle itself down). With someone on the floor, someone at the fan, and someone at the power, focus the fan. **DO NOT ATTEMPT TO ADJUST THE FAN WHILE IT IS RUNNING!**
8. Remove excess chain with bolt cutters.

Note: Due to continual product improvement, items are subject to change without notice.

PB Pedestal Base Assembly Instructions (34" Fan Only)

There are many applications for the Patterson Portable Base 34" fan. Use care when selecting locations for the fan. Do not place the fan on a sloped surface. Do not use if the finger guards are missing or damaged or not fitted properly. Do not use if the cord or connector has exposed wires or is damaged in any way.

1. If you ordered the fan head and the pedestal base together on the same purchase order, they will be shipped from the factory pre-assembled.
2. If you ordered these separately, begin mounting the fan head to the pedestal base by first securing the separate PB telescoping upright arms to the fan head stud bolt on either side of the fan housing, leaving them loose for free swinging.
3. After attaching the upright arms to the fan head (loosely) using a fork lift to pick up the fan head maneuver the fan head directly over the pedestal base and slowly lower until the upright telescoping arms slip into the fixed uprights of the base.
4. Inserted arm should measure 33"-34" in total height from floor, keeping fan level between the two uprights. Some tapping with a block of wood or hammer may be necessary.
5. Tighten nuts on stud bolts, connecting the upright arms to the fan head housing.

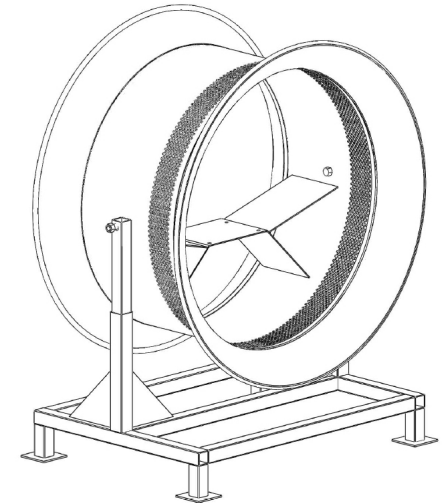
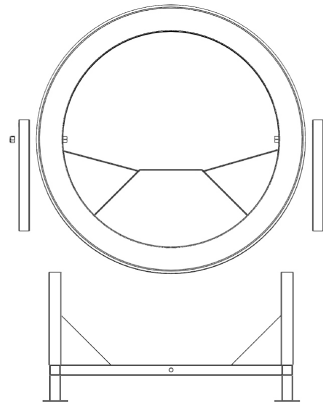
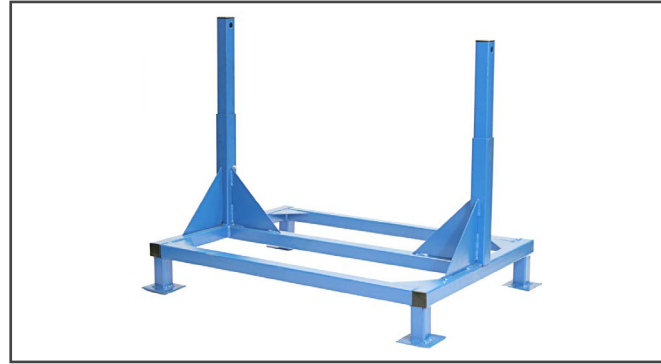

Note: Due to continual product improvement, items are subject to change without notice.

End of Assembly Instructions

Operating Instructions & Maintenance

Please read carefully before assembling, installing, operating or maintaining any Patterson Fan product. Protect yourself and others by observing all safety information. Failure to comply with assembly instructions, national electric codes or OSHA codes could result in personal injury and/or property damage. Retain instructions for future reference.



Operating Instructions

Disconnect power source before installing or servicing. Failure to disconnect power source can result in fire, shock or serious injury.

1. Patterson products should be installed and serviced by qualified technicians only.
2. Follow all local electrical and safety codes, as well as the National Electric Code (NEC) and the Occupational Safety and Health Act (OSHA) in the United States.
3. The unit should be installed, protected and fused in accordance with latest issue of the National Electrical Code, MEMA Standard Publication No. MG2 and local codes.
4. Motor must be securely and adequately grounded. This can be accomplished by wiring with a ground, metal-clad raceway system, using a separate ground wire connected to the bare metal of the motor frame, or other suitable means.
5. Always disconnect power source before working on or near a motor or its connected load. Lock open position and tag to prevent unexpected application of power.
6. In accordance with OSHA requirements, guarding is required if unit is mounted less than 7 feet above floor or where workers have access.
7. Keep hands and clothing away from moving parts.
8. Be careful when touching the exterior of an operating motor; it may be hot enough to cause injury. This condition is normal if operated at a rated load and voltage and built to operate at higher temperatures.
9. Protect power cable from coming into contact with sharp objects.
10. Do not tangle power cable and never allow cable to come in contact with oil, grease, hot surfaces or chemicals.
11. Make sure that the power source complies to the requirements of your equipment.

Single Phase Motors

The factory assembled fan head is equipped with a 12 foot long cord and connector. To turn on fan, plug it in; to turn off fan, unplug it.

Three Phase Motors

A cord and connector is not supplied with three phase motors. These fans will need to be fitted with an appropriate cord and connector or hard wired directly to a power source. If the fan is supplied with finger guards, the rear finger guard will need to be partially removed to access the motors internal wiring. Remove all but one of the self-tapping screws and place them in a safe place. You will use them again. Rotate the guards around on the single self-tapping screw. Wire the fan. Replace the guard using the saved self tapping screws.

When looking at the front of the fan, the blade should be turning clockwise. If it does not, the electrical connection wires may need to be reversed. If reversing the wires does not work, contact your factory representative.

Maintenance

All Patterson Fans are designed to be virtually maintenance free, but routine cleaning and inspection should be performed on a regular basis. Clean the fan of all dust, dirt and grease. Regular cleaning will keep the fan operating safely at optimal performance levels.

On an annual basis, we recommend that you inspect the following:

- Tightness of the blade
- Cracking of the blade around rivets, spider, and hub
- Integrity of motor mounts and welds
- Tightness of the safety finger/hand guards
- Tightness of bolts of mounting brackets
- Security of attachment to wall or other structural member
- Security of the safety chain

If you find any problems as a result of routine inspection or have any questions about assembly or operating instructions, consult the troubleshooting guide on the following page or call a factory sales representative at 800-768-3985.

For all parts, visit www.pattersonfan.com or contact Patterson Fan Company, Inc. direct at **800-768-3985**.

Troubleshooting

Warning: Electrical shock hazard, serious injury or death may occur. Disconnect from electrical supply before servicing these products.

Fan system: The head consist of four major parts: Housing, Guards, Motor and Blade. See troubleshooting array.

| PROBLEM | CHECK | SOLUTION |
|---|---|---|
| Fan won't run and makes no sound. | Power cord, extension cord, circuit breaker. Connections in motor junction box. Connections on motor capacitor. | Reconnect power, extension cord, reset breaker. Verify connections, match motor data plate. Reattach any loose connections. |
| Fan motor won't run and makes humming sound. | Connections in motor junction box. Confirm free rotation of the blade. Connections on motor capacitor. | Verify connection with motor data plate. Shift blade on motor shaft. Reattach any loose connections. Replace motor. |
| Breaker trips or fuse blows when fan is started. | Connections on motor capacitor. Blade rotation. Motor voltage connections match power source voltage. Inspect motor barrel for damage. | Reattach any loose connections. Shift blade on motor shaft. Check source voltage. Replace motor. |
| Motor overheating and shutting off. Restarting several minutes later. | Extension cord too small. Inlet air obstructed. Motor voltage connections match power source voltage. | Replace with heavier cord. Provide additional inlet clearance. Check source voltage. Replace motor. |

Please contact your Patterson Sales Representative for further questions: 800-768-3985



pattersonfan.com

800.768.3985