



**CFM**<sup>™</sup>  
CONTINENTAL FAN

*better AIRFLOW by DESIGN*<sup>™</sup>

# ***OEM Solutions & Custom Fans***



# PANEL & FLANGE FANS

## AFK DIRECT DRIVE FLANGE FANS

### FEATURES & BENEFITS

- Airfoil adjustable pitch cast aluminum impeller
- Unit can be built for supply or exhaust configurations
- Superior performance and sound characteristics
- Heavy gauge steel
- Baked polyester powder coat finish
- GRP (polypropylene) blades available
- Ideal for OEM applications or new construction
- Fully reversible design option available
- Advanced computerized selection program
- Sizes range from 12" to 42"
- Capacities to 34,000 cfm



### APPLICATIONS

- General ventilation
- Industrial drying
- Renewable energy
- OEM condensing units
- Marine / shipboard applications
- Circulation / recirculation units

### ACCESSORIES / OPTIONS

- Special coatings
- Special materials
- Mounting panel
- Motor side guard
- Propeller side guard
- Reverse flow construction
- Housing yoke with mounting bracket
- AMCA spark resistant construction
- Explosion proof & special duty motors

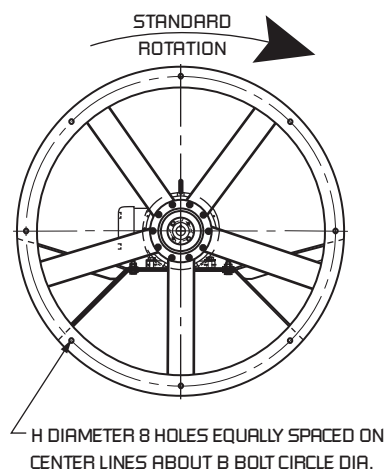
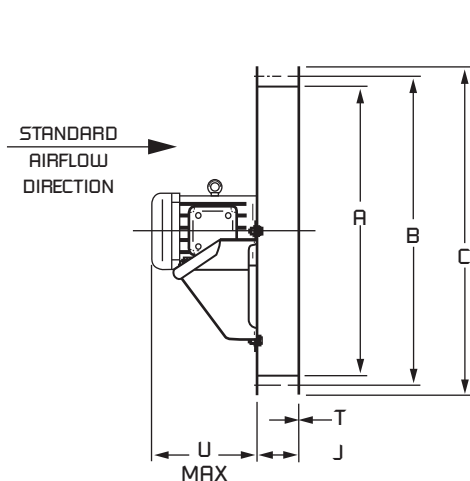

MODEL	DIMENSIONS IN INCHES*							
	A	B	C	H	J	T	U MAX	MAX MTR FRAME
AFK-12	12.2	13.8	15.0	0.44	3.0	0.06	11.5	143/5T
AFK-14	14.2	16.3	17.5	0.44	3.0	0.06	11.5	143/5T
AFK-16	16.2	18.0	19.5	0.44	4.0	0.08	11.5	143/5T
AFK-18	18.2	20.8	22.0	0.44	4.0	0.08	11.5	143/5T
AFK-21	21.2	23.3	24.5	0.44	4.0	0.08	11.5	143/5T
AFK-24	24.2	26.3	27.5	0.44	4.0	0.08	11.5	143/5T
AFK-27	27.2	29.3	31.0	0.44	4.0	0.08	13.3	182/4T
AFK-30	30.2	32.6	34.5	0.44	4.0	0.11	16.5	213/5T
AFK-32	32.2	34.4	36.5	0.44	4.0	0.11	16.5	213/5T
AFK-36	36.2	38.4	40.5	0.44	5.0	0.11	16.5	213/5T
AFK-42	42.2	44.6	46.5	0.44	5.0	0.11	21.5	254/6T

\*DO NOT USE FOR CONSTRUCTION

CONSULT FACTORY FOR CERTIFIED PRINTS

## APW DIRECT DRIVE PANEL FANS

### FEATURES & BENEFITS

- Spark resistant cast aluminum airfoil axial impeller
- Factory set adjustable pitch blades
- Baked polyester powder coat finish
- Heavy duty welded steel motor base and panel construction
- TEFC industrial duty motor
- Simple maintenance– no belts or pulleys
- Sizes range from 14" to 60"
- Capacities to 60,000 cfm



### APPLICATIONS

- General ventilation
- Petrochemical ventilation
- Parking garage ventilation
- Power plant ventilation
- Foundry ventilation
- Warehouse ventilation

### ACCESSORIES / OPTIONS

- Weather hood
- Bird screen
- Mounting boot
- Motor side guard
- Motor operated shutter
- Gravity shutter
- Special coatings & materials
- Reverse flow construction
- Explosion proof & special duty motors

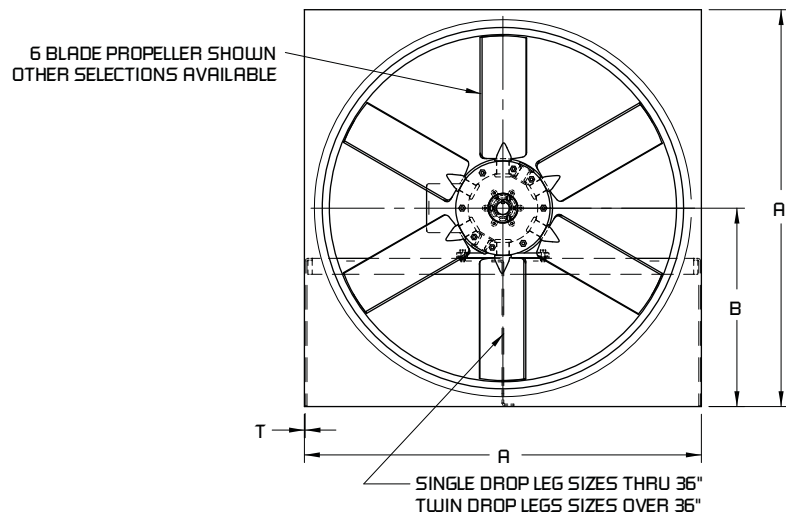
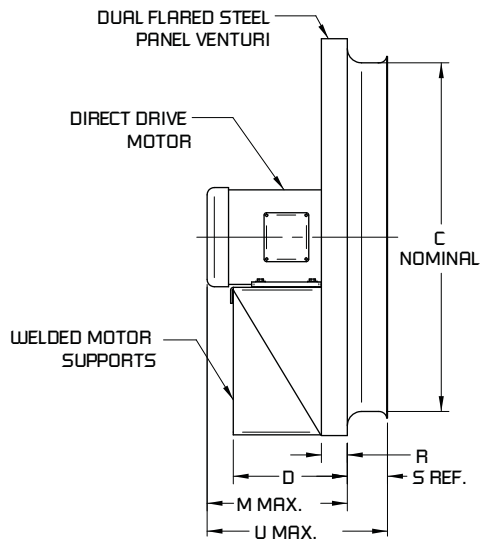

MODEL	DIMENSIONS IN INCHES*									MAX MTR FRAME
	A	B	C	D	M	R	S	T	U	
APW-14	18.0	9.0	14.8	9.3	11.1	2.0	1.8	0.1	12.9	56
APW-16	20.0	10.0	16.8	9.3	11.9	2.0	2.5	0.1	14.4	56
APW-18	22.0	11.0	18.8	10.1	13.1	2.0	2.5	0.1	15.6	182/4T
APW-21	24.0	12.0	20.8	9.6	12.8	2.0	3.3	0.1	16.1	182/4T
APW-24	30.0	15.0	24.8	12.7	15.2	2.8	3.6	0.1	18.8	213/5T
APW-27	32.0	16.0	27.9	12.7	15.2	2.8	4.0	0.1	19.2	213/5T
APW-30	36.0	18.0	31.0	12.8	15.2	2.8	3.7	0.1	18.8	213/5T
APW-36	42.0	21.0	36.9	17.4	19.8	2.8	4.3	0.1	24.1	254/6T
APW-42	48.0	24.0	42.9	17.4	19.8	2.8	4.8	0.1	24.6	254/6T
APW-48	54.0	27.0	48.9	19.7	23.6	2.8	4.8	0.1	28.3	284/6T
APW-54	60.0	30.0	55.0	22.4	26.9	2.8	5.0	0.1	31.9	324/6T
APW-60	Contact Factory									

AIRFLOW PERFORMANCE (CFM)	
MODEL	MAXIMUM
APW-14	3,000
APW-16	4,500
APW-18	6,000
APW-21	7,500
APW-24	12,000
APW-27	16,000
APW-30	22,000
APW-36	28,000
APW-42	36,000
APW-48	46,000
APW-54	60,000
APW-60	Contact Factory

\*DO NOT USE FOR CONSTRUCTION

CONSULT FACTORY FOR CERTIFIED PRINTS

# PANEL & FLANGE FANS

## APK DIRECT DRIVE PANEL FANS

### FEATURES & BENEFITS

- Airfoil adjustable pitch cast aluminum impeller
- Superior performance and sound characteristics
- Baked polyester powder coat finish
- GRP (polypropylene) blades available
- All-aluminum design available
- Custom designs available from 12" to 36"
- Capacities to 23,000 cfm from stock components

### APPLICATIONS

- OEM
- Replacement parts
- New construction

### ACCESSORIES / OPTIONS

- Inlet and outlet guards
- Motorized damper
- Weather hood
- Mounting boot
- Gravity damper
- Filter cabinet

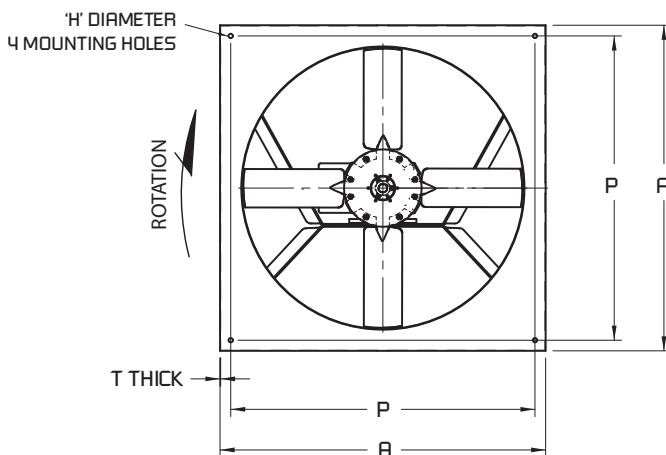
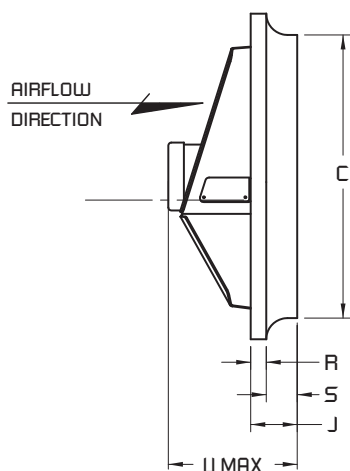

MODEL	DIMENSIONS IN INCHES*									MAX MTR FRAME
	A	C	H	J	P	R	S	T	U MAX	
APK-12	16	12.4	0.5	4.0	13.0	1.5	2.5	0.06	14.8	143/5T
APK-14	18	14.4	0.5	3.5	15.0	1.0	2.5	0.06	14.8	143/5T
APK-16	20	16.4	0.5	4.3	17.0	1.3	3.0	0.06	14.8	143/5T
APK-18	22	18.4	0.5	4.8	19.0	1.3	3.5	0.08	14.8	143/5T
APK-21	25	21.4	0.5	5.5	22.0	1.5	4.0	0.08	14.8	143/5T
APK-24	28	24.4	0.5	5.5	25.0	1.5	4.0	0.08	16.8	182/4T
APK-27	32	27.4	0.5	5.5	29.0	1.5	4.0	0.08	16.8	182/4T
APK-30	36	30.4	0.4	5.5	33.3	2.0	3.5	0.08	20.6	213/5T
APK-36	42	36.4	0.4	6.0	39.3	2.0	4.0	0.08	26.1	213/5T

\*DO NOT USE FOR CONSTRUCTION

CONSULT FACTORY FOR CERTIFIED PRINTS

## SEF SHUTTER MOUNT WALL FANS

### FEATURES & BENEFITS

- Suitable for through the wall installation
- 2 or 3 speed operation, pull chain switch
- 120 VAC single phase 60 Hz operation
- UL/CSA approved motor
- Totally enclosed permanently lubricated motor
- External junction box
- Aluminum fan blades in galvanized frame
- Plated steel spiral wire guard
- Mounts directly to inside wall
- Eliminates need for external framing
- Sizes: 10" to 30"
- Capacities to 3950 cfm



### APPLICATIONS

- Warehouse ventilation
- General ventilation
- Factory ventilation
- Equipment room ventilation

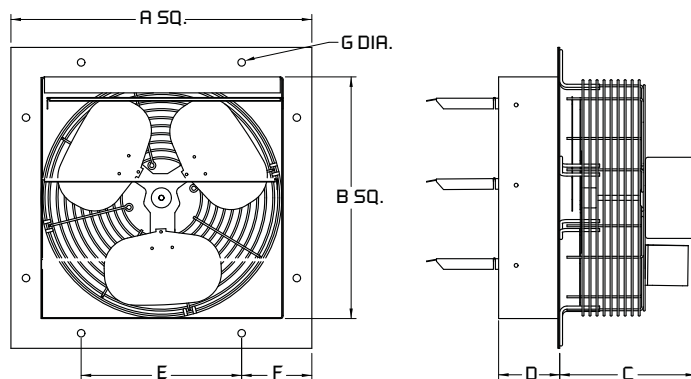

MODEL	MTR HP	AMPS (HIGH)	AIRFLOW PERFORMANCE (CFM)		
			HIGH	MEDIUM	LOW
SEF-10	1/12	1.0	680	540	460
SEF-12	1/12	1.1	825	710	560
SEF-14	1/8	2.0	1520	1400	1250
SEF-16	1/8	2.1	2100	1900	1700
SEF-18	1/8	2.2	2300	2100	1850
SEF-20	1/4	2.3	2925	N/A	2380
SEF-24	1/4	2.5	3400	N/A	2770
SEF-30	1/4	2.7	3950	N/A	3080

MODEL	DIMENSIONS IN INCHES*							WT (LBS)
	A	B	C	D	E	F	G	
SEF-10	13.0	10.1	6.1	2.5	6.0	3.5	0.3	11
SEF-12	15.0	12.1	7.1	2.5	8.0	3.5	0.3	16
SEF-14	17.0	14.1	7.9	2.5	10.0	3.5	0.3	17
SEF-16	19.0	16.1	7.9	2.5	12.0	3.5	0.3	18
SEF-18	21.0	18.1	7.6	2.5	14.0	3.5	0.3	25
SEF-20	23.0	20.1	9.4	2.5	16.0	3.5	0.3	34
SEF-24	27.0	24.1	9.9	2.5	20.0	3.5	0.3	47
SEF-30	33.0	30.1	9.9	3.0	26.0	3.5	0.3	54

\*DO NOT USE FOR CONSTRUCTION

CONSULT FACTORY FOR CERTIFIED PRINTS



# PANEL & FLANGE FANS

## GEF GUARD MOUNT WALL FANS

### FEATURES & BENEFITS

- Suitable for through the wall installation
- 2 or 3 speed operation, pull chain switch
- 120 VAC single phase 60 Hz operation
- UL/CSA approved motor
- Totally enclosed permanently lubricated motor
- External junction box
- Aluminum fan blades
- Plated steel spiral wire guard
- Mounts directly to inside wall
- Sizes: 10" to 30"
- Capacities to 3950 cfm



### APPLICATIONS

- Warehouse ventilation
- General ventilation
- Factory ventilation
- Equipment room ventilation
- Mechanical room exhaust
- Equipment cooling

### ACCESSORIES / OPTIONS

- WS wall shutter
  - Aluminum blades; galvanized steel frame

MODEL	MTR HP	AMPS (HIGH)	AIRFLOW PERFORMANCE (CFM)		
			HIGH	MEDIUM	LOW
GEF-10	1/12	1.0	680	540	460
GEF-12	1/12	1.1	825	710	560
GEF-14	1/8	2.0	1520	1400	1250
GEF-16	1/8	2.1	2100	1900	1700
GEF-18	1/8	2.2	2300	2100	1850
GEF-20	1/4	2.3	2925	N/A	2380
GEF-24	1/4	2.5	3400	N/A	2770
GEF-30	1/4	2.7	3950	N/A	3080

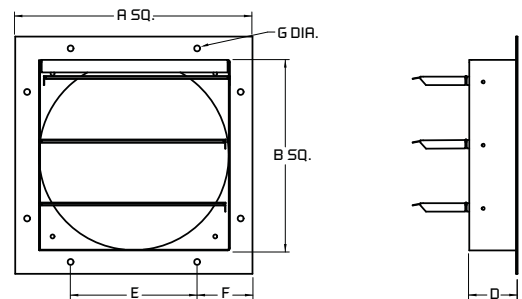
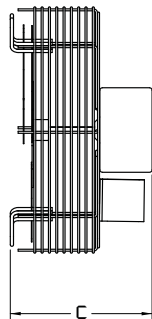
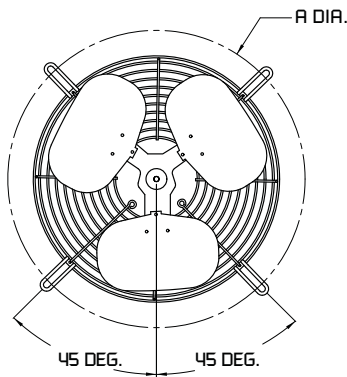

MODEL	DIMENSIONS IN INCHES*		WT (LBS)
	A	C	
GEF-10	14.1	5.8	11
GEF-12	16.4	6.8	12
GEF-14	18.2	7.6	17
GEF-16	20.3	7.6	18
GEF-18	22.6	7.3	19
GEF-20	25.4	9.1	34
GEF-24	29.0	9.6	38
GEF-30	34.8	9.6	42

MODEL	DIMENSIONS IN INCHES*					
	A	B	D	E	F	G
WS-10	13.0	10.1	2.5	6.0	3.5	0.3
WS-12	15.0	12.1	2.5	8.0	3.5	0.3
WS-14	17.0	14.1	2.5	10.0	3.5	0.3
WS-16	19.0	16.1	2.5	12.0	3.5	0.3
WS-18	21.0	18.1	2.5	14.0	3.5	0.3
WS-20	23.0	20.1	2.5	16.0	3.5	0.3
WS-24	27.0	24.1	2.5	20.0	3.5	0.3
WS-30	33.0	30.1	3.0	26.0	3.5	0.3

\*DO NOT USE FOR CONSTRUCTION

CONSULT FACTORY FOR CERTIFIED PRINTS

## PEF PANEL MOUNT WALL FANS

### FEATURES & BENEFITS

- Suitable for through the wall installation
- 2 or 3 speed operation, pull chain switch
- 120 VAC single phase 60 Hz operation
- UL/CSA approved motor
- Totally enclosed permanently lubricated motor
- External junction box
- Aluminum fan blades
- Plated steel spiral wire guard
- Mounts directly to inside wall
- Sizes: 10" to 30"
- Capacities to 3950 cfm



### APPLICATIONS

- Warehouse ventilation
- General ventilation
- Factory ventilation
- Equipment room ventilation
- Mechanical room exhaust
- Equipment cooling

### ACCESSORIES / OPTIONS

- WS wall shutter
  - Aluminum blades; galvanized steel frame

MODEL	MTR HP	AMPS (HIGH)	AIRFLOW PERFORMANCE (CFM)		
			HIGH	MEDIUM	LOW
PEF-10	1/12	1.0	680	540	460
PEF-12	1/12	1.1	825	710	560
PEF-14	1/8	2.0	1520	1400	1250
PEF-16	1/8	2.1	2100	1900	1700
PEF-18	1/8	2.2	2300	2100	1850
PEF-20	1/4	2.3	2925	N/A	2380
PEF-24	1/4	2.5	3400	N/A	2770
PEF-30	1/4	2.7	3950	N/A	3080

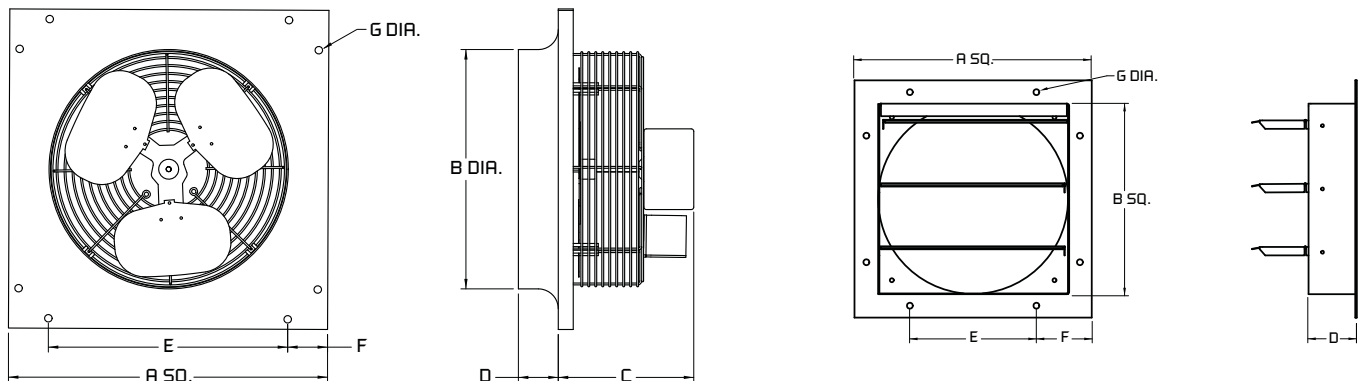

MODEL	DIMENSIONS IN INCHES*							WT (LBS)
	A	B	C	D	E	F	G	
PEF-10	12.5	10.3	6.1	1.0	3.8	4.4	0.3	11
PEF-12	14.5	12.3	7.1	1.0	5.8	4.4	0.3	17
PEF-14	17.0	14.3	7.9	1.5	8.3	4.4	0.3	17
PEF-16	19.0	16.3	7.9	1.9	10.3	4.4	0.3	18
PEF-18	21.0	18.1	7.6	1.8	12.3	4.4	0.3	26
PEF-20	23.0	20.3	9.4	1.8	14.3	4.4	0.3	34
PEF-24	28.0	24.3	9.9	2.5	18.3	4.4	0.3	48
PEF-30	34.0	30.3	9.9	2.5	24.3	4.4	0.3	55

MODEL	DIMENSIONS IN INCHES*					
	A	B	D	E	F	G
WS-10	13.0	10.1	2.5	6.0	3.5	0.3
WS-12	15.0	12.1	2.5	8.0	3.5	0.3
WS-14	17.0	14.1	2.5	10.0	3.5	0.3
WS-16	19.0	16.1	2.5	12.0	3.5	0.3
WS-18	21.0	18.1	2.5	14.0	3.5	0.3
WS-20	23.0	20.1	2.5	16.0	3.5	0.3
WS-24	27.0	24.1	2.5	20.0	3.5	0.3
WS-30	33.0	30.1	3.0	26.0	3.5	0.3

\*DO NOT USE FOR CONSTRUCTION

CONSULT FACTORY FOR CERTIFIED PRINTS

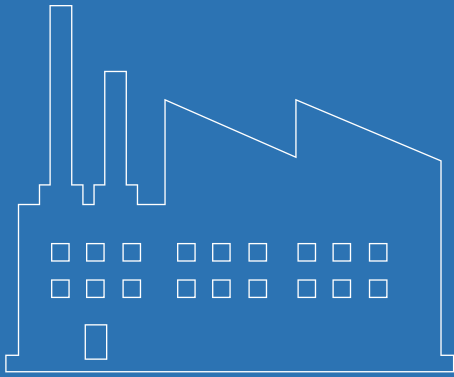

***Industrial Fans  
& Blowers***

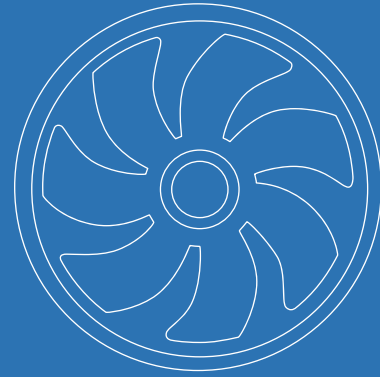

***OEM Solutions  
& Custom Fans***



***Commercial Fans  
& Dampers***



***Residential Fans &  
Air Purifiers***



## OEM Solutions & Custom Fans

Continental Fan Manufacturing Inc.  
203 Eggert Road  
Buffalo, New York 14215

Continental Fan Canada Inc.  
12-205 Matheson Blvd E  
Mississauga, Ontario L4Z 3E3

Continental Fan Manufacturing Inc.  
6274 Executive Blvd.  
Dayton, Ohio 45424

1-800-779-4021 • [www.continentalfan.com](http://www.continentalfan.com)

Distributed by: