

Economical fans for light duty, general exhaust requirements. Well suited for factory or warehouse ventilation.

FEATURES

- Heavy duty 4-blade fabricated steel propellers standard
- Sealed pillow block ball bearings
- Fans shipped fully assembled and factory tested - ready for field installation
- Motors are high quality industrial grade, available in single or three phase - totally enclosed fan cooled
- Belt driven for quiet operation

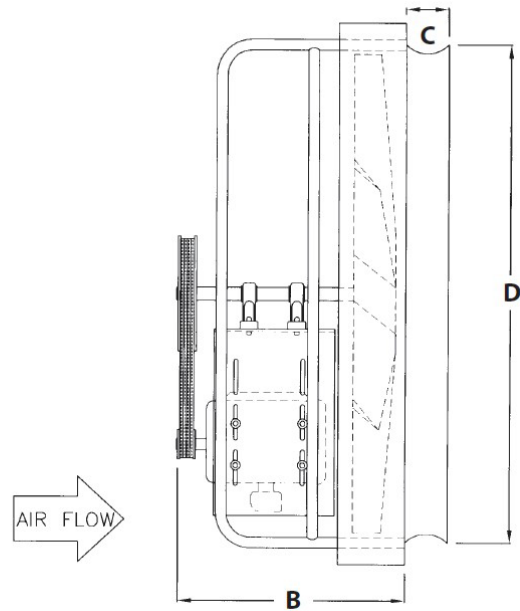
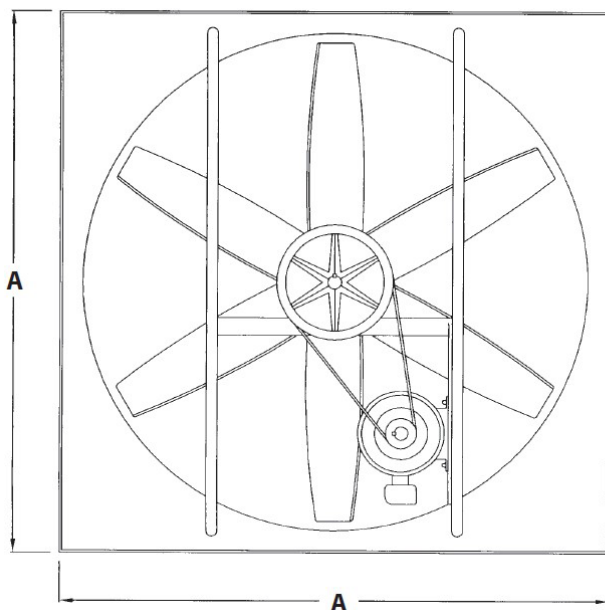

DIMENSIONS

Model	A	B	C	D
N624	30"	18"	3-1/2"	25-1/2"
N630	36"	18"	3-1/2"	31-1/2"
N636	42"	20"	4"	37-1/2"
N634	48"	20"	4-1/4"	44"
N648	54"	22"	4-1/2"	50-1/2"

OPTIONAL ACCESSORIES

- Fan & shutter mounting box
- Front & rear OSHA compliant guards
- All aluminum gravity exhaust shutter
- Weather hood with birdscreen

PERFORMANCE DATA

Blade Diameter	Model	Horse Power	RPM	Free Air	1/8" SP	1/4" SP	1/2" SP	3/4" SP
24"	N624-B	1/3	825	5300	4700	3800	2200	1400
	N624-C	1/2	925	6200	5700	5000	4000	2600
	N624-D	3/4	1050	7000	6600	6000	4400	3000
	N624-E	1	1175	7800	7400	6900	5700	3500
30"	N630-B	1/3	570	7500	6000	3400	700	-
	N630-C	1/2	625	8500	7100	4400	2700	1300
	N630-D	3/4	725	10000	9100	7600	5100	1800
	N630-E	1	825	11000	10400	9300	5500	2800
36"	N636-B	1/3	425	9000	6800	3500	500	-
	N636-C	1/2	500	10500	8800	5900	3600	2000
	N636-D	3/4	575	11900	10500	8500	5500	4000
	N636-E	1	650	13100	11800	10200	6900	5000
42"	N642-D	3/4	430	14000	11500	7600	4800	3300
	N642-E	1	490	15400	13100	10400	6400	4600
	N642-F	1-1/2	550	17200	15300	12400	7900	5300
48"	N648-D	3/4	350	17000	12000	7000	2000	-
	N648-E	1	400	19100	16000	10900	6400	4000
	N648-F	1-1/2	460	22000	19000	14000	10000	6000

MODEL NUMBER SCHEMATIC

